

Values nom. in mm / Drawing shows 3-Wire version

Electrical Characteristics					
Hall Series	—	1	2	3	4
Type	—	2 Wire Switch Current output	2 Wire Switch Current output	3 Wire Switch Voltage output	3 Wire Switch Voltage output
Supply Voltage*1 (Absolute)	Vdc	-18 ... +28	-18 ... +28	-18 ... +28	-18 ... +28
Supply Voltage (Operate)	Vdc	+3.0 ... +24	+3.0 ... +24	+2.7 ... +24	+2.7 ... +24
Supply Voltage (Overvoltage)	Vdc (max.)	40	40	40	40
Output (High Voltage)	Vdc (min.)	N/A	N/A	Sinking output	Sinking output
Bon @25°C - typ.	mT	9.4	6.0	12.0	5.5
Boff @25°C - typ.	mT	7.6	4.1	7.0	3.7
Supply Current (Vsup 12V)	mA	5.0 - 7.0	2.5 - 5.0	1.1 - 2.4	1.1 - 2.4
Switching Speed	kHz	12	12	12	12
Magnetical Characteristics					
Hall Series	—	1	2	3	4
Sensitivity Gauss	Gauss (typ.)	94	60	120	55
Environmental Characteristics					
Operating temperature	°C	-40...+100	-40...+100	-40...+100	-40...+100
Material Information					
Hall Series	—	1	2	3	4
Housing material	—	PBT+20GF	PBT+20GF	PBT+20GF	PBT+20
Housing color	—	red	red	red	red
Cable type	—	UL1569	UL1569	UL1569	UL1569
Cable AWG	—	24	24	24	24
Cable color	—	black/red	black/red	blue/black/red	blue/black/red
<b>Available Magnet</b>	<b>Customized version (available upon request)</b>				<b>Approvals</b>
Various	Hall Type / Cable type / Cable color / Cable length / Cable ends / Housing color / Connector assembly				RoHS, REACH

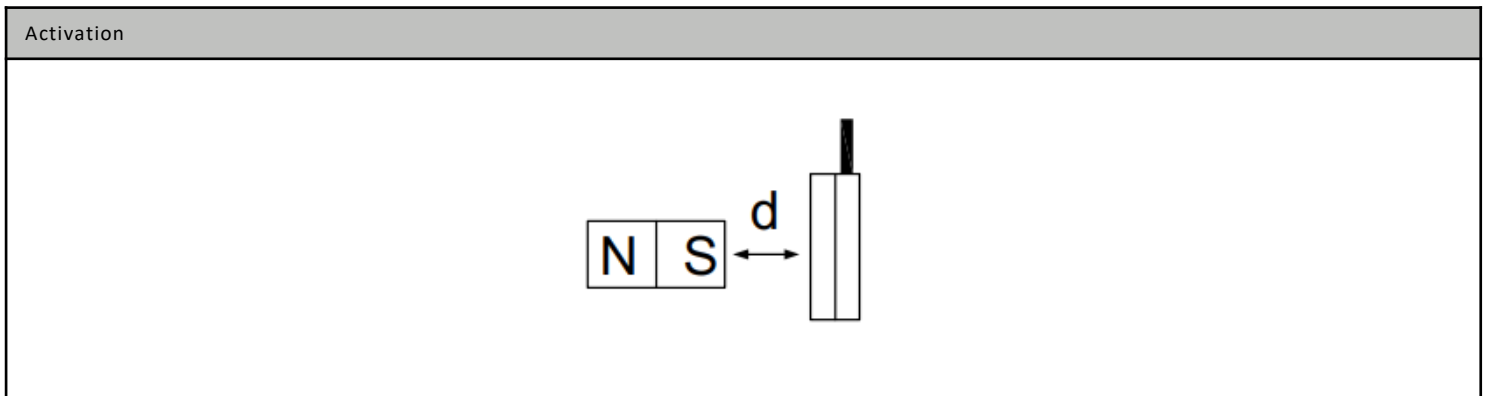
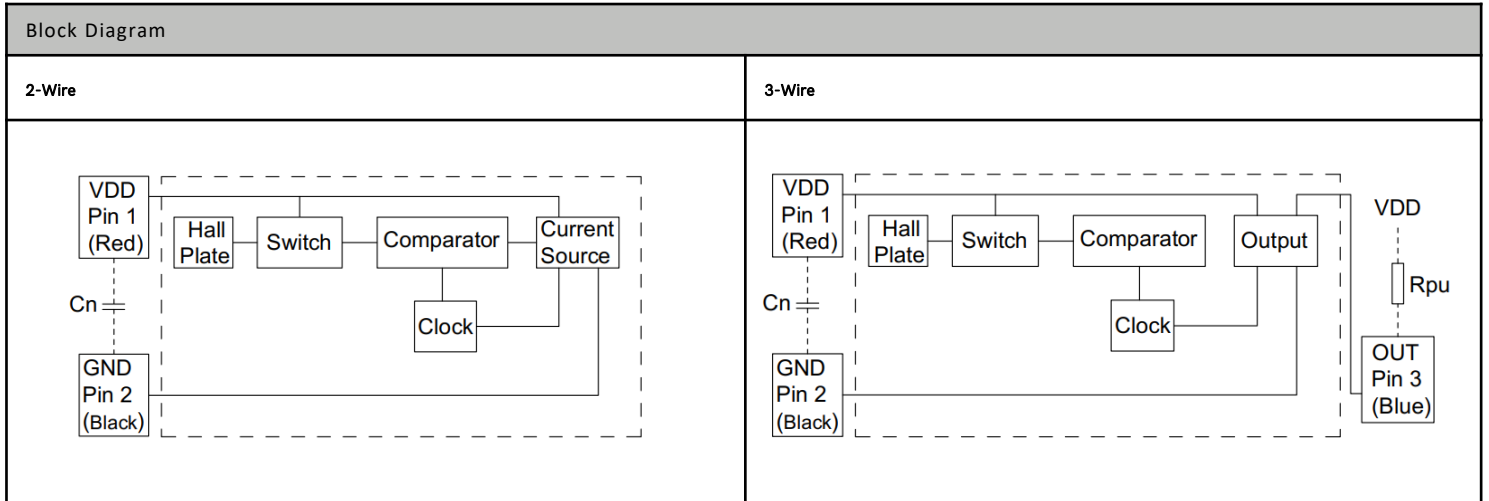

**Activation distance**

Hall Series	—	1	2	3	4
Distance (d)	mm (typ.) *2	15.0	18.5	13.0	19.0

**Cable Length Option**

1	150mm +/-5
2	300mm +/-10
3	500mm +/-10

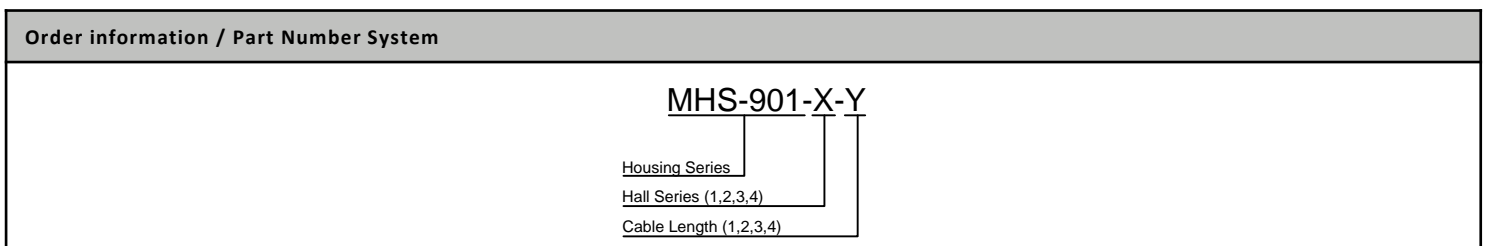

**NOTES**

- \*1 – As long as Tj (Junction Temperature) max. is not exceeded
- \*2 – Average values using masetec reference magnet NdFeB 21x7x4.7mm

Add capacitor Cn (see Block Diagram) close to the sensor for transient suppression if required  
 Add resistor Rpu (see Block Diagram) for sinking output. The Qpu value should be calculated using your supply voltage while keeping the on state current at level below the maximum.  $A_{pu} = VDD/I_o - R_{pu} = 12Vdc/10mA=1.2$